



Chiltern House Stocking Lane Hughenden Valley
High Wycombe Buckinghamshire HP14 4ND UK

t +44 (0) 1494 569 800 f +44 (0) 1494 564895
e cif@chilternfire.co.uk w www.chilternfire.co.uk

CONFIDENTIAL

Test Report : Chilt/RF06047 Revision A

**A fire resistance test performed on
a one and a half leaf single acting doorset and a single
leaf single acting doorset with glazing**

Test conducted in accordance with BS 476 : Part 22 : 1987

Test Date: 13 April 2006

Primary Sponsor :
Beamfast Ltd
Unit F, Forest Industrial Park
Forest Road
Hainault
Essex
IG6 3HL

Secondary Sponsor :
Balfour Beatty Construction Ltd
24 Ravelston Terrace
Edinburgh
EH4 3TP

Page 1 of 18

Opinions and interpretations expressed herein are outside the scope of UKAS accreditation

This document is confidential and remains the property of Chiltern International Fire Ltd

The legal validity of this report can only be claimed on the presentation of the complete report. All pages of original copies of this document are embossed with the Chiltern International Fire Ltd name and logo.

This is an electronic copy of the report which is not embossed and is uncontrolled if printed.



No. 1762



Contents

	Page No
1 Introduction	3
2 Specification	3
2.1 Door leaves	3
2.2 Door perimeter gaps	3
2.3 Closer forces	3
3 Test conditions	4
4 Test results	5
4.1 Furnace temperature curve	5
4.2 Unexposed face temperature curves	5
4.3 Door distortion data	7
4.4 Observations	8
4.5 Times to failure	10
5 Limitations	10
Description of construction	11
Figure 1	15
Figure 2	16
Figure 3	17
Figure 4	18

*The legal validity of this report can only be claimed on presentation of the complete report.
All pages of original copies of this document are embossed with the Chiltern International Fire Ltd name and logo.
This is an electronic copy of the report which is not embossed and is uncontrolled if printed.*

1 Introduction

The doorsets were manufactured and supplied for test by the client and delivered on 11 April 2006. Chiltern International Fire Ltd constructed a timber stud/plasterboard clad partition and Beamfast Ltd installed the doorsets into the partition.

2 Specification

Details of the specimen are shown in Figures 1 to 4.

2.1 Door leaves

The left doorset was designated doorset A and consisted of a leaf measuring 2040mm high x 927mm wide x 54mm thick and a half leaf measuring 2040mm high x 462mm wide x 54mm thick. The right doorset was designated doorset B and measured 2040mm high x 925mm wide x 54mm thick. All leaves were hung to open in towards the furnace, which is considered to be the most onerous direction based on experience of testing doors of similar construction. It is therefore the opinion of the laboratory that the test results can be applied to doors opening in either direction. The results of this test were obtained from doorset A not fitted with a latch and doorset B fitted with a latch but disengaged.

2.2 Door perimeter gaps

The gaps between the edge of the doors and frames were measured prior to test. A total of 31 readings were taken. The measurements (in mm) are given in Figure 4.

2.3 Closer forces

Measured in accordance with FTSG Resolution No 63.

		Opening force (Nm)	Closing force (Nm)
Doorset A	Left leaf	29	17
	Right leaf	27	20
Doorset B		29	18

*The legal validity of this report can only be claimed on presentation of the complete report.
All pages of original copies of this document are embossed with the Chiltern International Fire Ltd name and logo.
This is an electronic copy of the report which is not embossed and is uncontrolled if printed.*

3 Test conditions

- 3.1 Where areas of the test specification are ambiguous or open to interpretation the Fire Test Study Group Resolutions No's 51, 63, 70, 71, 72 and 78 have been followed (further specific details are available on request). These Resolutions provide basis of common agreements between the fire test laboratories which are members of this Group.
- 3.2 The ambient temperature of the test area at commencement of test was 15°C.
- 3.3 After the first 5 minutes of the test, the furnace pressure was maintained at 0 ± 2 Pa with respect to atmosphere, at a point 1m from the notional floor level.
- 3.4 The furnace was controlled to follow the temperature/time relationship specified in BS 476: Part 20: 1987 as closely as possible, using the average of six thermocouples suitably distributed within the furnace. The temperatures recorded are shown graphically in Section 4.1.
- 3.5 The temperature of the unexposed face of doorset A was monitored by means of five thermocouples fixed to the surface of the door leaves, and four thermocouples attached to the frame, one at midheight on each jamb and one centrally located above each leaf on the frame head.

The temperature of the unexposed face of doorset B was monitored by means of five thermocouples fixed to the surface of the door leaf, and three thermocouples attached to the frame, one at midheight on each jamb and one centrally located above each leaf on the frame head. An additional thermocouple was fitted to the glazing.

The thermocouple positions are shown in Figure 4. The average temperature of each door leaf and maximum temperature of each doorset are shown graphically in Section 4.2.

4 Test results

The following data and observations were recorded during the test.

4.1 Furnace temperature curve

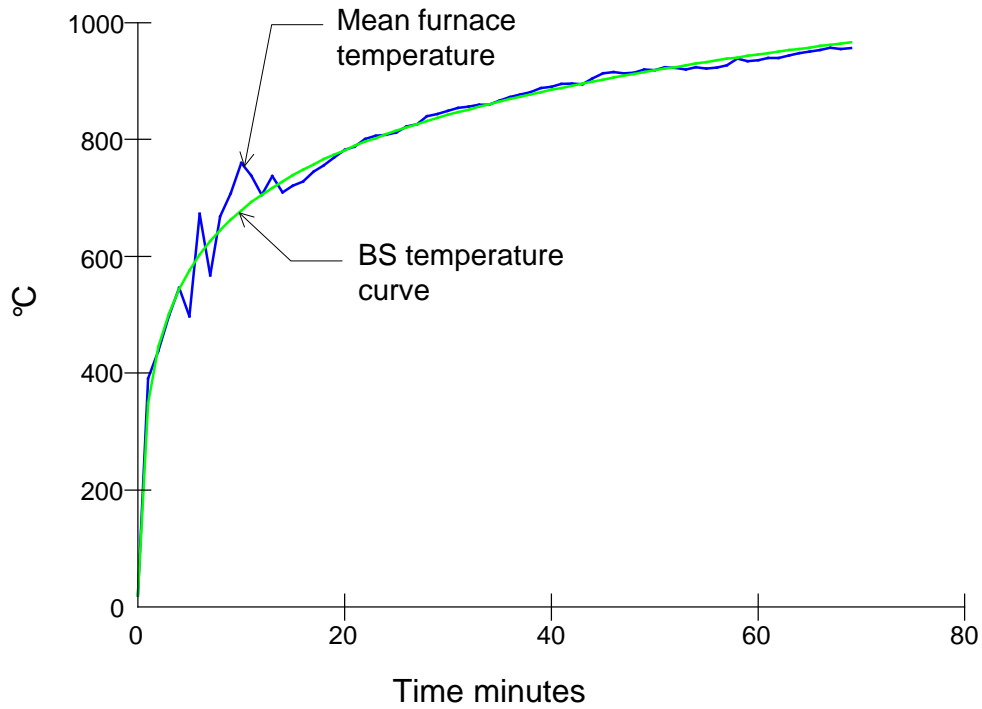

4.2 Unexposed face temperature curves

Doorset A

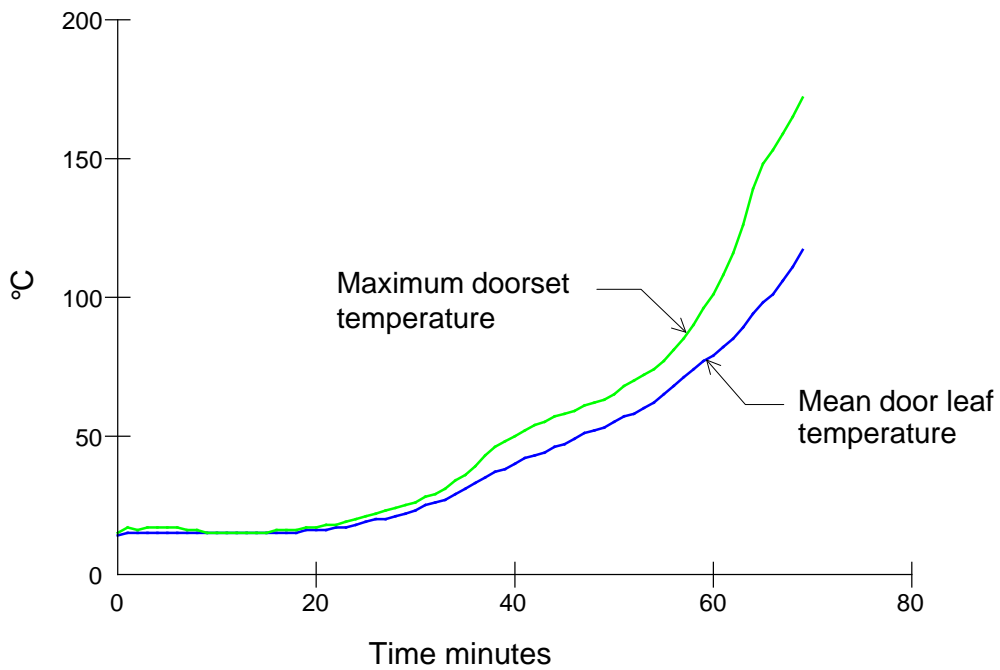

*The legal validity of this report can only be claimed on presentation of the complete report.
 All pages of original copies of this document are embossed with the Chiltern International Fire Ltd name and logo.
 This is an electronic copy of the report which is not embossed and is uncontrolled if printed.*

Doorset B - leaf

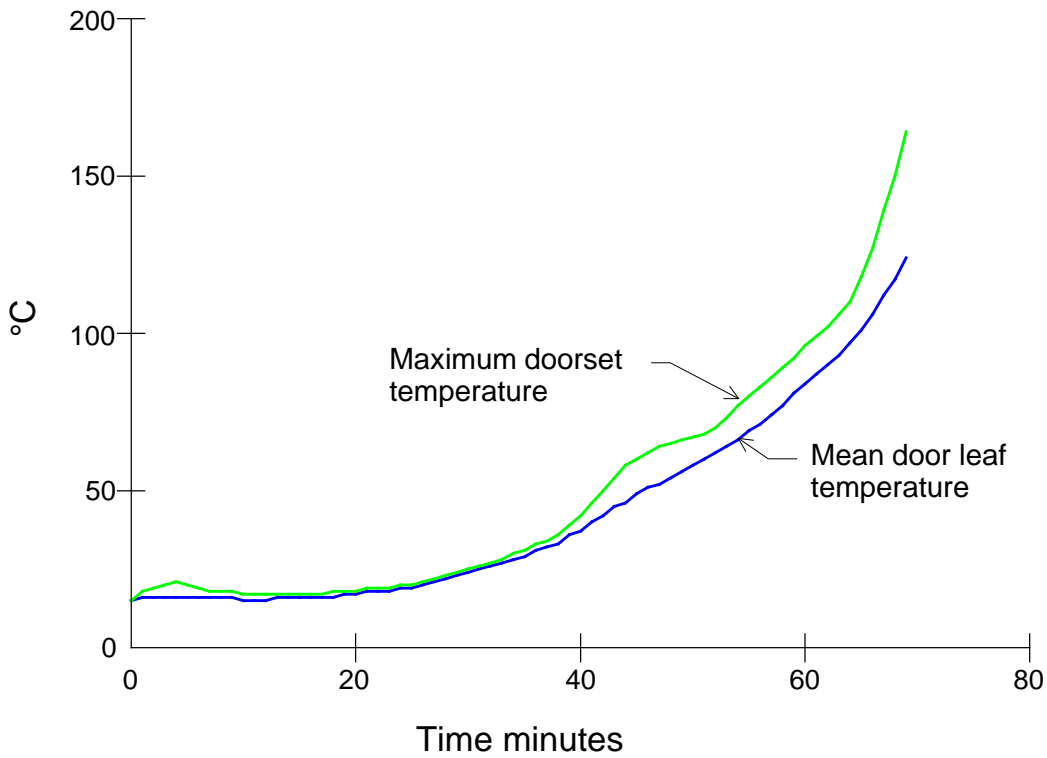

Doorset B - glass

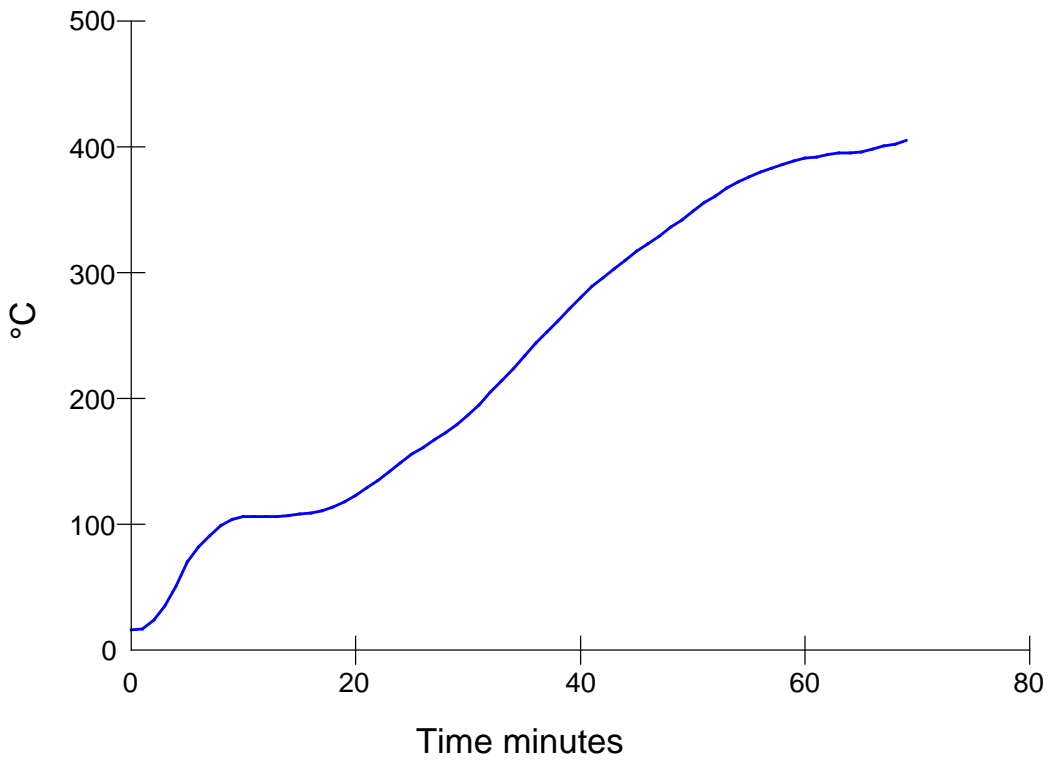

*The legal validity of this report can only be claimed on presentation of the complete report.
 All pages of original copies of this document are embossed with the Chiltern International Fire Ltd name and logo.
 This is an electronic copy of the report which is not embossed and is uncontrolled if printed.*

4.3 Door distortion data

The following tables show the distortion of the doors in mm with an accuracy of ± 1 mm. A positive measurement indicates distortion towards the fire.

A negative measurement indicates distortion away from the fire.

J, K and L give vertical movement of the door, a negative reading indicates that the door has dropped.

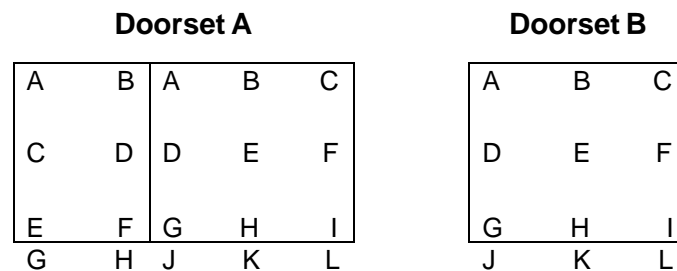

Doorset A - left hand leaf (hung on the left and opening in towards the fire)

Time	A	B	C	D	E	F	G	H
15	1.5	0	0	-2	0.5	-0.5	1	0
30	1	1.5	0.5	3.5	1.5	3	1	-0.5
45	1.5	6	-1.5	-7	2.5	-1.5	-1	-2.5
60	2.5	8.5	5	-39	11	-7	-3.5	-5

Doorset A - right hand leaf (hung on the right and opening in towards the fire)

Time	A	B	C	D	E	F	G	H	I	J	K	L
15	0	-0.5	0	-2	0	0	-3.5	-2	-1	-0.5	0.5	0
30	4	0.5	0	6.5	4	1	3.5	-1	-1	-1.5	-0.5	0.5
45	7.5	0.5	1.5	-7.5	-10	-1	-1.5	-4.5	-1	-4	-3.5	-2
60	11	-0.5	4.5	-62.5	-	-	-31.5	-44	-8	-	-	-4

Doorset B (hung on the left and opening in towards the fire)

Time	A	B	C	D	E	F	G	H	I	J	K	L
15	2	2.5	3	-1.5	-3	-3	0.5	3	6	-0.5	-1.5	-0.5
30	2	2.5	6	-2	-4	-2	1	2.5	9	-1	-1.5	-1
45	4	3	8.5	-5	-14.5	-4.5	4	6	17.5	-1.5	-3	-2
60	5	2.5	14	-8	-17	-9	4	5	20	-2.5	-3.5	-3

Where a dash (-) applies, a distortion reading could not be taken

The legal validity of this report can only be claimed on presentation of the complete report.

All pages of original copies of this document are embossed with the Chiltern International Fire Ltd name and logo.

This is an electronic copy of the report which is not embossed and is uncontrolled if printed.

4.4 Observations

All comments relate to the unexposed face unless otherwise specified.

Time (minutes)	Comments
00.00	Test started.
01.30	Doorset A, right leaf, there is smoke issuing from the top hanging corner of the leaf.
01.45	Doorset A, there is smoke issuing from the top of the meeting edge of the leaves. Doorset B, there is smoke issuing from the top hanging corner of the leaf.
03.50	Both doorsets, there is an increase in the level of smoke issuing. Doorset B, the glass intumescent is reacting.
06.30	Both doorsets, there is an increase in the level of smoke issuing.
10.40	Both doorsets, there is a decrease in the level of smoke issuing.
15.40	Doorset A, left leaf, there is smoke issuing from the middle and top hinge positions and top hanging corner of the leaf. Doorset A, right leaf, there is smoke issuing from the top and middle hinge positions, top hanging corner and top of the meeting edge of the leaf. Doorset B, there is smoke issuing from the top hinge position, top hanging corner and across the head of the leaf.
18.00	Doorset B, there is discolouration at the top hinge position due to smoke issuing.
19.40	Doorset A, there is discolouration at the top of the meeting edge of the leaves due to smoke issuing.
49.00	Both doorsets, no change.
52.00	Doorset B, there is smoke issuing from the latch position and the bottom closing corner of the leaf has distorted beyond the second intumescent strip (unexposed face).
54.00	Doorset B, there is smoke issuing from around the glazing.
56.30	Doorset A, left leaf, there is smoke issuing from the bottom hinge position.
60.00	Both doorsets satisfactory.
63.20	Doorset A, there is a glow visible at the middle of the meeting edge of the leaves.
64.40	Doorset A, there is a glow visible at the bottom hanging corner of the leaf.

*The legal validity of this report can only be claimed on presentation of the complete report.
All pages of original copies of this document are embossed with the Chiltern International Fire Ltd name and logo.
This is an electronic copy of the report which is not embossed and is uncontrolled if printed.*

- 66.00 Doorset A, both leaves, there is discolouration of the leaf face at mid point.
- 67.34 Doorset A, a cotton pad integrity test was performed at the top of the meeting edge of the leaf, no failure.
- 67.50 Doorset A, there is a small area of burn through on the left leaf.
- 68.37 Doorset A, there is continuous flaming from the top of the meeting edge of the leaf thereby constituting **integrity failure**.
- 69.00 Test terminated.

*The legal validity of this report can only be claimed on presentation of the complete report.
All pages of original copies of this document are embossed with the Chiltern International Fire Ltd name and logo.
This is an electronic copy of the report which is not embossed and is uncontrolled if printed.*

4.5 Times to failure

Doorset A was tested in accordance with BS 476: Part 22: 1987, Method 6, Determination of fire resistance of fully insulated doorsets and shutter assemblies and Doorset B was tested in accordance with BS 476: Part 22: 1987, Method 7, Determination of fire resistance of partially insulated doorsets and shutter assemblies. The requirements of the standard were satisfied for the following periods:

	Doorset A	Doorset B
Integrity	68 (sixty eight) minutes	69 (sixty nine) minutes*
Insulation	68 (sixty eight) minutes	69 (sixty nine) minutes* **

* No failure had occurred at the time of test termination at 69 minutes



** In accordance with the note to clause 7.6.1.1 of BS 476: Part 22: 1987, the glazing has not been evaluated for insulation

5 Limitations

The results only relate to the behaviour of the element of construction under the particular conditions of test; they are not intended to be the sole criteria for assessing the potential fire performance of the element in use nor do they reflect the actual behaviour in fires.

The results of this test were obtained using the door to frame gaps recorded in Figure 4. The fire resistance performance of doors of this design may change if substantially different gaps are employed.

The specification and interpretation of fire test methods are the subject of ongoing development and refinement. Changes in associated legislation may also occur. For these reasons it is recommended that the relevance of test reports over 5 years old should be considered by the user. CIFL will be able to offer, on behalf of the legal owner, a review of the procedures adopted for a particular test to ensure that they are consistent with current practices, and if required may endorse the test report.

Signature:		
Name:	Mark Cummings	Jonathan Osborn
Title:	Senior Test Engineer	Technical Manager
Date of issue:	24 November 2006	

Revision A - November 2006 - Page 13, Intumescent Seals, both doorsets, amendment of thickness of intumescent used under hinge blades

*The legal validity of this report can only be claimed on presentation of the complete report.
All pages of original copies of this document are embossed with the Chiltern International Fire Ltd name and logo.
This is an electronic copy of the report which is not embossed and is uncontrolled if printed.*

Description of construction (refers to Figures 1 to 4)

Leaf - both doorsets

		Species/type	Dimensions (mm)	Density (kg/m ³)	Moisture (% w/w)	Key to figures
Leaf		Pacific Rim Wood (UK) Ltd Flamebreak 60	54 thick	-	-	1
Adhesive	Lipping	Urea formaldehyde	-	-	-	-
Lippings - all edges		Jatoba hardwood	12 thick	955*	10	2

* Stated density, not checked by laboratory

** Nominal density

Frame - both doorsets

		Species/type	Dimensions (mm)	Density (kg/m ³)	Moisture (% w/w)	Key to figures
Head & jambs		Jatoba hardwood	99 wide x 58 thick including 14 deep stop	955*	11.5	3
Head to jamb jointing detail		Mortise and tenon - screwed	-	-	-	-
Stops		Jatoba hardwood - integral	14 deep x 43 wide	955*	11.5	-
Frame to supporting construction fire stopping detail		Mineral wool capped each side with 3mm Hilti 611A graphite mastic	Nominally 18 thick	-	-	-
Frame to supporting construction fixing detail		5No steel wood screws per jamb	100 long	-	-	-
Architrave		None fitted	-	-	-	-
Threshold		Non combustible	-	-	-	-

* Stated density not checked by laboratory

*The legal validity of this report can only be claimed on presentation of the complete report.
All pages of original copies of this document are embossed with the Chiltern International Fire Ltd name and logo.
This is an electronic copy of the report which is not embossed and is uncontrolled if printed.*

Intumescent materials - doorset A

		Make/type	Size (mm)	Location	Key to figures
Door edges - meeting edge, left leaf only		2No Mann McGowan Fabrications Ltd Pyrostrip 500FPSA	15 x 4	Centrally fitted in meeting edge of left leaf spaced 10 apart	4
Frame reveal	Head	Mann McGowan Fabrications Ltd Pyrostrip 500FPSA	30 x 4	Centrally fitted in frame reveal	5
	Jambs	2No Mann McGowan Fabrications Ltd Pyrostrip 500FPSA	15 x 4	Centrally fitted in frame reveal spaced 9 apart	6
Around hinges		Partially interrupted	-	Hinge blade fully interrupts one seal and partially interrupts the other seal, leaving 10mm of strip running alongside the blade	-
Under hinge blade		Astroflame (Fire Seals) Ltd intumescent sheet	2 thick	Fitted under hinge blades on leaf and frame	-
Encasing latch body		Astroflame (Fire Seals) Ltd intumescent sheet	0.8 thick	Wrapped around the latch body	-
Under latch forend		Astroflame (Fire Seals) Ltd intumescent sheet	0.8 thick	Fitted under the latch forend	-
Under latch keep		Astroflame (Fire Seals) Ltd intumescent sheet	0.8 thick	Fitted under the latch keep	-
Around latch forend		Fully interrupted	-	Latch forend fully interrupts both intumescent strips	-

Intumescent materials - doorset B

		Make/type	Size (mm)	Location	Key to figures
Door edges		None fitted	-	-	-
Frame reveal	Head	Mann McGowan Fabrications Ltd Pyrostrip 500FPSA	30 x 4	Centrally fitted in frame reveal	7
	Jambs	2No Mann McGowan Fabrications Ltd Pyrostrip 500FPSA	15 x 4	Centrally fitted in frame reveal spaced 9 apart	8
Around hinges		Partially interrupted	-	Hinge blade fully interrupts one strip and partially interrupts the other strip, leaving 10mm of strip running alongside the blade	-
Under hinge blade		Astroflame (Fire Seals) Ltd intumescent sheet	2 thick	Fitted under hinge blades on leaf and frame	-

Continued/....

*The legal validity of this report can only be claimed on presentation of the complete report.
All pages of original copies of this document are embossed with the Chiltern International Fire Ltd name and logo.
This is an electronic copy of the report which is not embossed and is uncontrolled if printed.*

	Make/type	Size (mm)	Location	Key to figures
Encasing latch body	Astroflame (Fire Seals) Ltd intumescent sheet	0.8 thick	Wrapped around latch body	-
Under latch forend	Astroflame (Fire Seals) Ltd intumescent sheet	0.8 thick	Fitted under latch forend	-
Under latch keep	Astroflame (Fire Seals) Ltd intumescent sheet	0.8 thick	Fitted under latch keep forend	-
Around latch forend	Fully interrupted	-	Latch forend fully interrupts both intumescent strips	-
Glazing perimeter	Sealmaster Ltd Fireglaze compound	4 thick	Fitted between the glass and beading	18
	Sealmaster Ltd Fireglaze GL60 liner	2 thick	Fitted to the edge of the leaf (see Figures 2 and 3)	19

Ironmongery - doorset A

	Make/type	Size (mm)	Location	Key to figures
Hinges	3No Royde & Tucker Hi-Load H208 bearing type hinges per leaf	101 x 36 (blade size)	Fitted 150mm, 970mm, and 1787mm from head of leaf to top of hinge blade	9
Closer	Ingersoll Rand 2130BT Briton slide arm overhead closer	315 x 65 (footprint size)	Fitted to exposed face as per manufacturer's specification	10
Latch	None fitted	-	-	-

Ironmongery - doorset B

	Make/type	Size (mm)	Location	Key to figures
Hinges	3No Royde & Tucker Hi-Load H208 bearing type hinges	101 x 36 (blade size)	Fitted 150, 970 and 1787 from head of leaf	11
Closer	Ingersoll Rand 2130BT Briton slide arm overhead closer	315 x 65 (footprint size)	Fitted to exposed face as per manufacturer's specification	12
Latch	SAG stainless steel mortise latch (LOI)	24 x 230 (forend size)	Fitted 1100mm from head of leaf to centre of the latch nib	13
Furniture	Stainless steel lever handles (FOI)	55 x 235 (footprint size)	Fitted appropriate to the latch	14

*The legal validity of this report can only be claimed on presentation of the complete report.
All pages of original copies of this document are embossed with the Chiltern International Fire Ltd name and logo.
This is an electronic copy of the report which is not embossed and is uncontrolled if printed.*

Glazing - doorset B

	Make/type	Size (mm)	Location	Key to figures
Glass type	Pilkington Pyrodur	13 thick	Fitted centrally in the width and 284 from the head	15
Sight size	-	200 wide x 445 high	-	-
Overall aperture size	-	252 wide x 497 high	-	-
Expansion allowance	-	3 all edges	-	-
Beading	Jatoba hardwood	31 high x 22 deep including a 5 x 5 bolection return and a 15° chamfer	Fitted to both faces around perimeter of glazing	16
Beading fixings	Steel pins	60 long	Fitted 40 from corners at 50 centres on horizontal edge and 80 centres on vertical edge	17

*The legal validity of this report can only be claimed on presentation of the complete report.
All pages of original copies of this document are embossed with the Chiltern International Fire Ltd name and logo.
This is an electronic copy of the report which is not embossed and is uncontrolled if printed.*

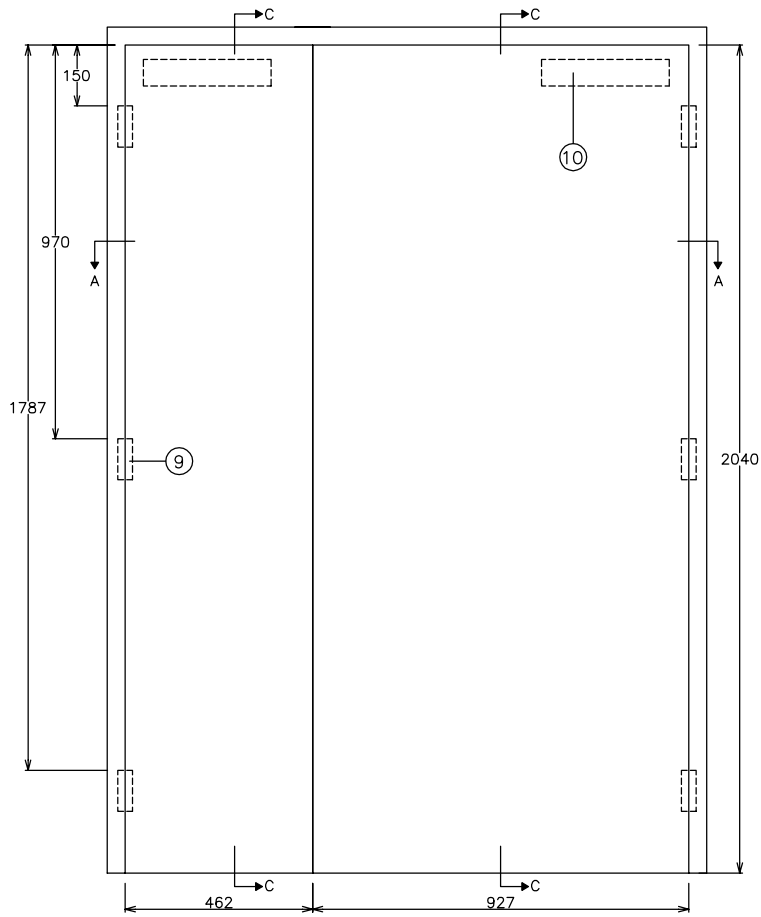

Doorset A

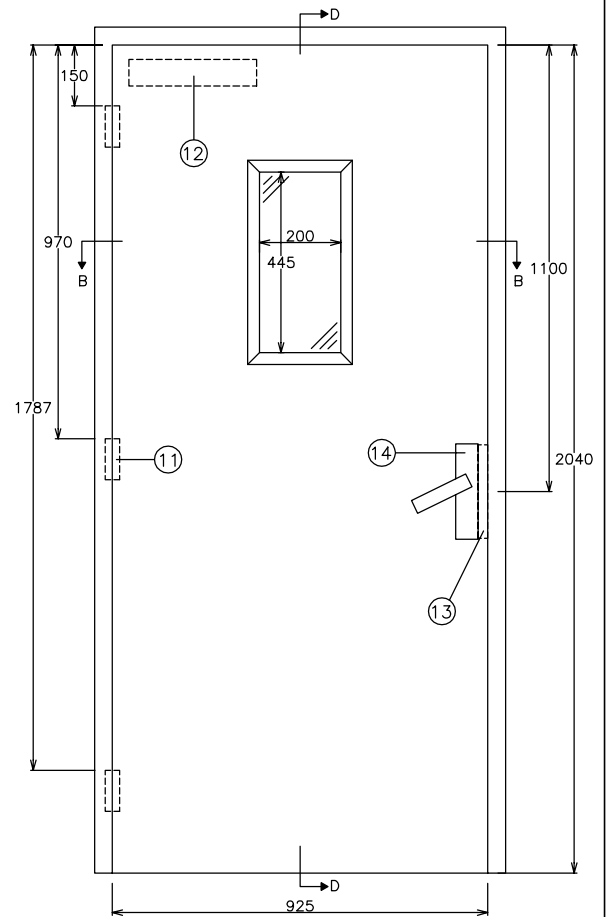

Doorset B



Chiltern House, Stocking Lane, Hughenden Valley
 High Wycombe, Buckinghamshire, HP14 4ND, UK.
 Tel: +44 (0)1494 569800 Fax: +44 (0)1494 564895

Title Unexposed face elevation showing ironmongery positions (All dimensions in mm)

Date Drawn 02/05/06	Drawn By SP	Scale NTS
Project No. Chilt/RF06047 Rev A		Page 15 of 18

Section A-A

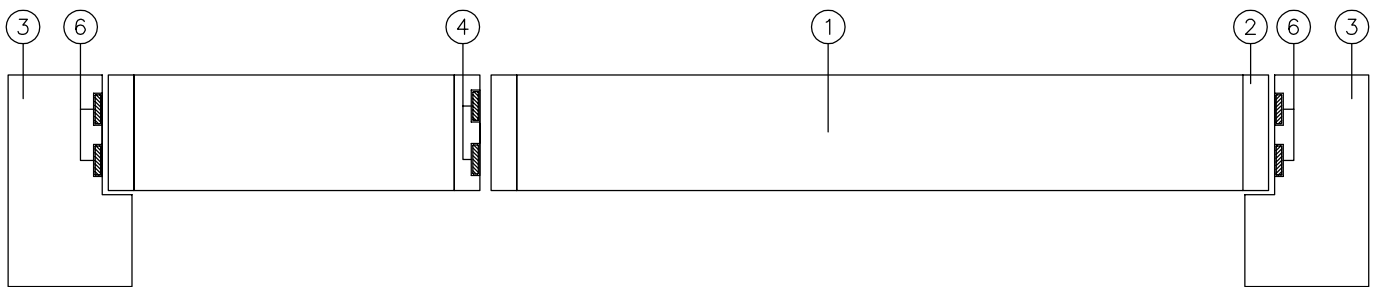

Section B-B

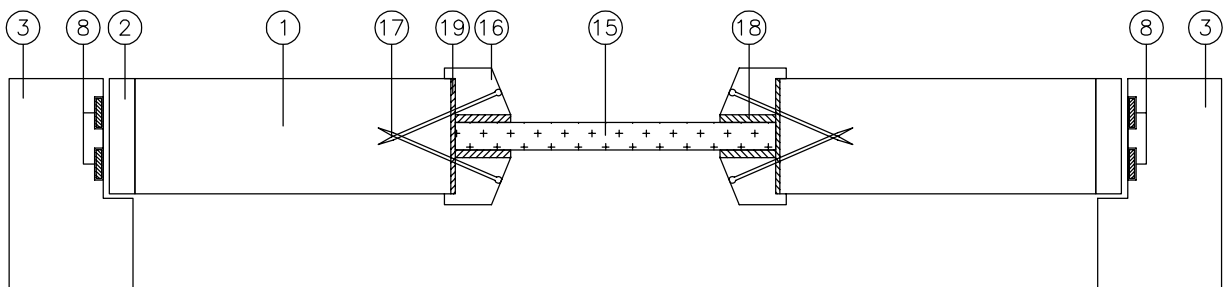

Chiltern House, Stocking Lane, Hughenden Valley
High Wycombe, Buckinghamshire, HP14 4ND, UK.
Tel: +44 (0)1494 569800 Fax: +44 (0)1494 564895

Title

Horizontal cross sections

Date Drawn
03/05/06

Drawn By
SP

Scale
NTS

Project No.
Chilt/RF06047 Rev A

Page 16 of 18

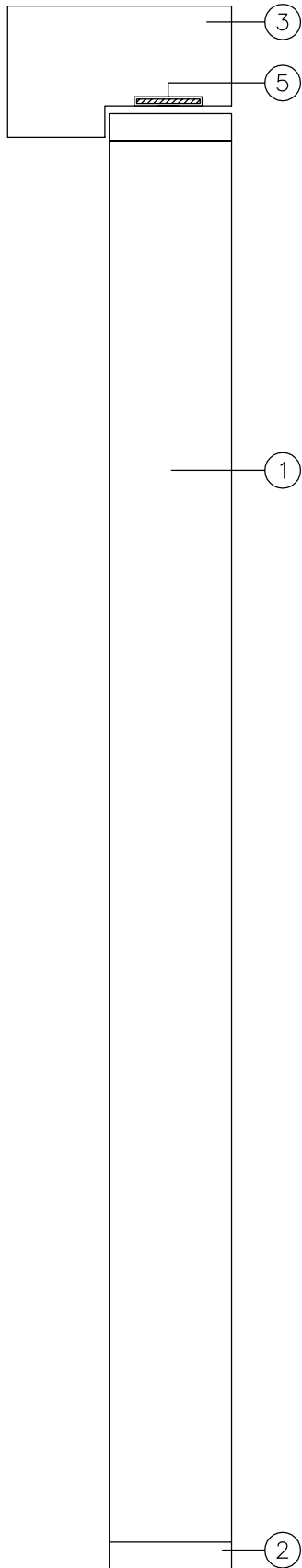

Section C-C

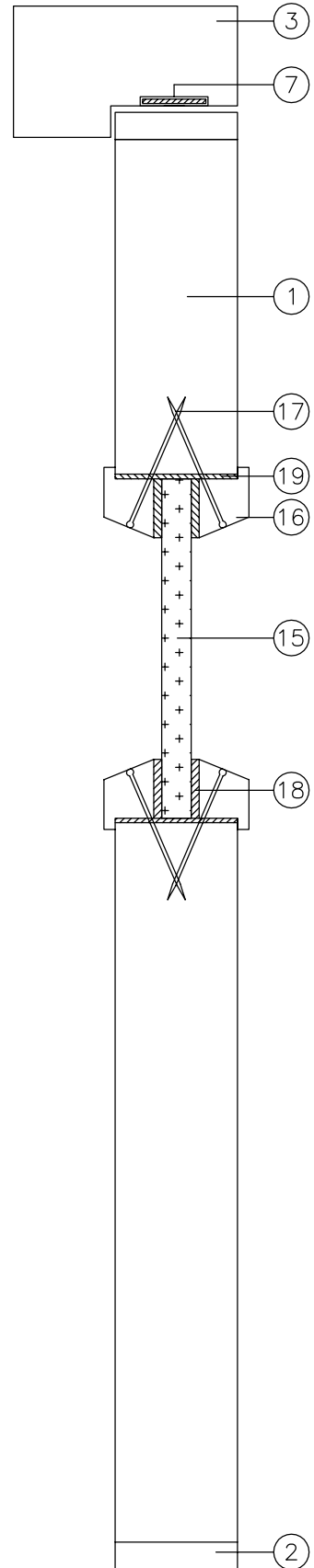

Section D-D



Chiltern House, Stocking Lane, Hughenden Valley
 High Wycombe, Buckinghamshire, HP14 4ND, UK.
 Tel: +44 (0)1494 569800 Fax: +44 (0)1494 564895

Title

Vertical cross sections

Date Drawn
 03/05/06

Drawn By
 SP

Scale
 NTS

Project No.
 Chilt/RF06047 Rev A

Page 17 of 18

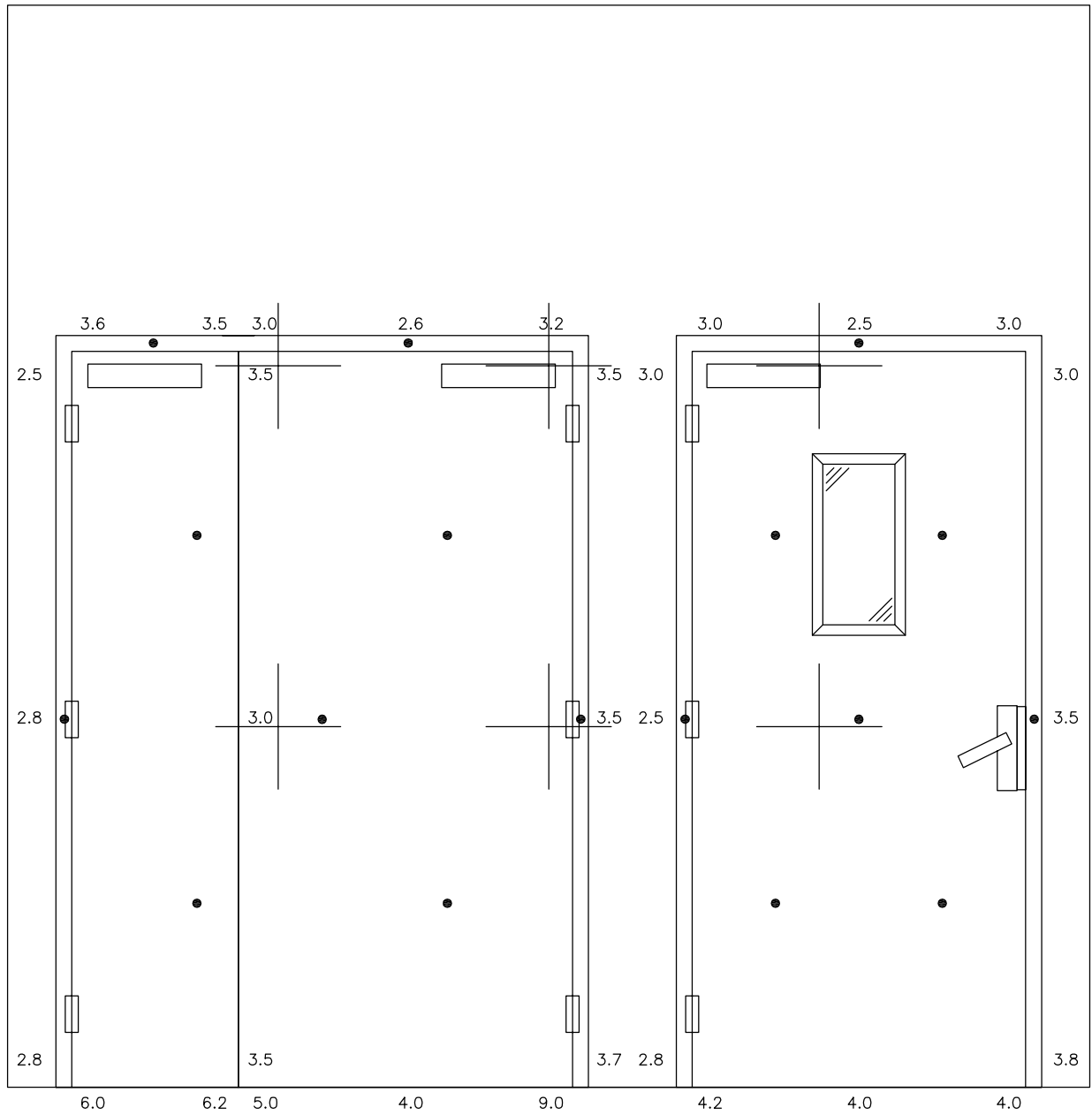

+ : Furnace Thermocouples
 • : Unexposed Face Thermocouples

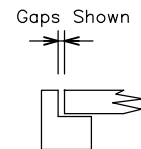

Viewed From Unexposed Face



Chiltern House, Stocking Lane, Hughenden Valley
 High Wycombe, Buckinghamshire, HP14 4ND, UK.
 Tel: +44 (0)1494 569800 Fax: +44 (0)1494 564895

Title Thermocouple positions and door gaps
 (All dimensions in mm)

Date Drawn 02/05/06	Drawn By SP	Scale NTS
Project No. Chilt/RF06047 Rev A		Page 18 of 18